



Rough & Semi-Finishing, Indexable Ball Nose

Ball Nose Series 2BW & 1BW for 3D Contour Roughing & Semi-Finishing



General Machining, Mold & Die & Aerospace

- Robustly designed insert pocket, exceptionally strong helical cutting edge
- Smartly designed cutter bodies with large chip gullets and directed thru-coolant standard
- Heavy-duty side cutting insert has 4 cutting edges for larger diameters
- Technology designed to deliver, economy, strength and performance

PRO-BALL™ BALL NOSE SERIES 2BW3Y & 1BW7W

Diameters
1.000" to 2.000"

Depth of Cut Range
Up to 2.700



Ramping

Pocketing

Corkscrew

Contouring

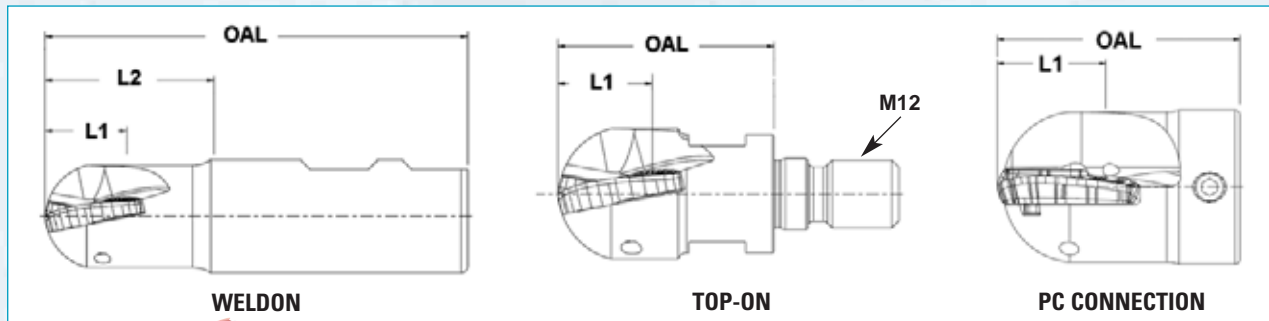

MORE DIAMETERS COMING SOON!

Nominal Diameter	EDP Number	Cutter Number	L ₁ Depth of Cut	L ₂ Extension	OAL	Shank Type/ Diameter
1.000	3028604	1BW7W-10015X7R01	0.500	—	1.500	M12 Top-On
1.000	3028603	1BW7W-1001580R01	0.500	1.500	3.750	1.000 Weldon
1.000	3029094	1BW7W-10037E1R01	0.500	3.750	6.750	1.000 Weldon
2.000	3028259	1BW7Y-2003076R01	1.700	—	3.000	PC Connection
2.000	3029095	2BW3Y-20070E4R01	2.700	7.000	11.000	2.000 Weldon
2.000	3028260	2BW3Y-20040E4R01	2.700	4.000	8.000	2.000 Weldon

PRO-BALL™ INSERT



Cutter Diameter	Description	Part Number	EDP Number	Insert Radius	Maximum DOC	Number of Indexes	Grade	Insert Screw
1.000	Ball Insert	NCET250400R	5812782	0.500	0.50	2	IN2005	SE02-63
2.000	Ball Insert	NDET500800R	5812783	1.000	1.00	2	IN2005	SM60-180-00
2.000	Side Station	DGM324R001	5830052	n/a	n/a	4	IN2005	SM40-140-00

OPERATING GUIDELINES

Series 2BW3Y, 1BW7W, 1BW7Y					Grades	
Material		Brinell Hardness	SFM	Feed per Insert	IN2005	Coolant
Aluminum	6061 T-6, 7075 T-6	-	1000-3000	.003-.008	•	Yes
Cast Iron	Gray	150-250	500-1200	.002-.008	•	No
	Nodular	150-250	400-800	.002-.008	•	
Steel	Low Carbon 1018-8620	150-250	600-1200	.005-.020	•	No
	High Carbon F-6180	250-400	400-600	.005-.020	•	
	Alloyed Steel 4140	150-300	400-800	.005-.025	•	
	Tool Steel P-20-H13	Up to 460	400-800	.005-.025	•	
Stainless Steel	300 Series, 304, 316	-	400-800	.003-.015	•	No
	400 Series 15-5 PH, 17-4 PH	Up to 320	500-1000	.003-.015	•	
	13-8 PH	-	200-400	.003-.015	•	Yes
Nickel Alloys	Inconel 600, 706, 718, 903 Hastelloy	75-120	75-120	.003-.010	•	Yes
Titanium	6AL-4V	-	80-150	.002-.006	•	Yes

Note: Feed and speed recommendations are starting operating parameters. They are only guidelines from which further optimization should take place. Operating parameters are influenced by many machining variables. These variables may cause for reductions in feeds and speed or dramatic increases. Additionally, DOC and WOC may need to be revised to optimize the tools performance.

